

Battery Bin Installation Instructions

For Rubber Bumper MGB's

1. Please read and follow these instructions; your safety may depend on it!
2. You have purchased the "ultimate" MGB battery bin. It is custom molded just for '74 1/2-'80 MGBs. This bin will protect your MGB from battery acid, and protect your battery from road grime! It is made of high quality polyethylene and will last for many years. Please follow the instructions below for best results.
3. This bin fits many 12V sizes: 21, 22, 26, 45, 58, 62, 70. It does not fit size 24.
4. Remove current battery from MGB.
5. Clean your battery, cable ends, and battery frame. A wire brush works well, sometimes with a grease solvent like Gunk. Wash your frame down with a solution of baking soda and water to neutralize any residual acid (2 Tb. soda/cup water). For any bare rust, sandblasting and painting is best, but a much easier solution is to use a rust-neutralizing primer (that just brushes on) like Extend®, found at your auto supplier.
6. Not all MGBs are wired the same, so it is left to you to provide openings for battery cables. This is easy to do: just draw with a marker the openings you desire, and then use a razor knife to cut them (make sure they are large enough to pass your cable ends through -- see sketch A). Do not seal these openings up afterwards. They provide ventilation for hydrogen gas escaping from the battery.
7. Now, just slide the bin into your MGB, drop in your battery, and pull your cables through the openings you cut (it is helpful to tie strings to your cables and pull them through instead of pushing them through from under your MGB). Fasten your cables to your battery.
8. Good tip: now use your fingers to coat your clean battery cable ends and battery terminals with Vaseline®. This coating will prevent corrosion, and last a long time!
9. Safety Fast! Your battery must always be secure. The original tie-down may be used (see sketch B), or you might use a method of your own design (will your battery posts contact the metal lid in event of a roll-over?!).

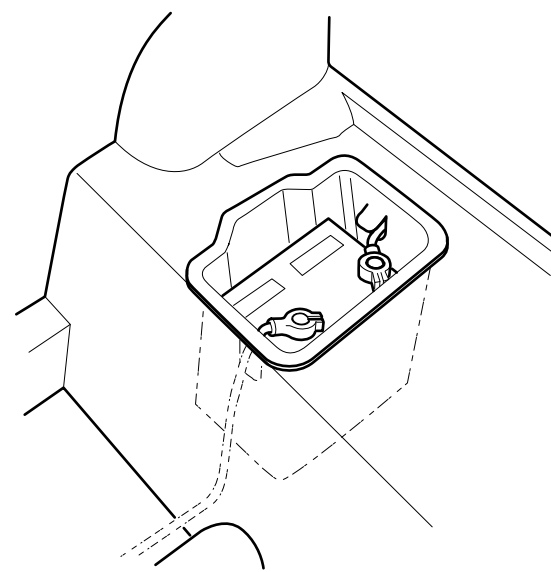

Sketch A

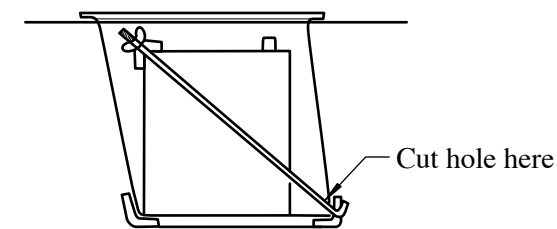

Sketch B

