

# Bonnet Lift Kit Installation Instructions

**Thank you** for purchasing our Kit! It is designed to fit:

1. **1970-80 Spitfire** (Mk IV and 1500).  
OR
2. **MK3 GT6**
3. It *will* fit all MK3 Spitfires & 1500s (71-78), although we make a different kit intended for these earlier Spitfires.

## **This Kit contains:**

2 Gas Springs	4 Lock Washers
1 LH Bracket	4 Flat Washers
1 RH Bracket	4 Nuts
4 Ball Studs	

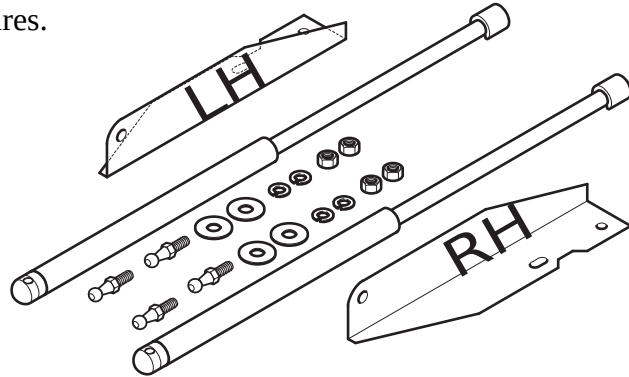

1. Attach a Ball Stud to the RH Bracket as shown.
2. Open your bonnet and set the factory prop.
3. Remove the 2 bolts and washers shown in the illustration on page 2, then fasten the RH bracket with them (be sure to tuck your wiring harness under/behind the bracket for tidiness).
4. Place a large washer on a Ball Stud and install it in the proper hole (see illustration, top of page 2). You may be able to turn the Ball Stud and thread it all the way flush without drilling the hole larger. Otherwise drill the hole ever so slightly larger. Now apply one more Large Washer and a Lock Washer and fasten tightly with a Nut.

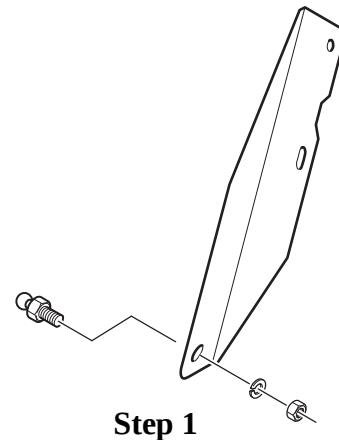

5. Twist the Gas Spring such that the end-fittings are facing the same direction. The "tube end" of the Gas Spring should be oriented "up" so as to keep the seals lubricated for long life. Press\* the Gas Spring onto the top Ball Stud, and then by lifting the bonnet slightly, you can press the bottom end of the Gas Spring onto the lower Ball Stud.

\*Hint: pressing directly on isn't the best way to attach. It's better to "rotate" or "shoe horn" them on.

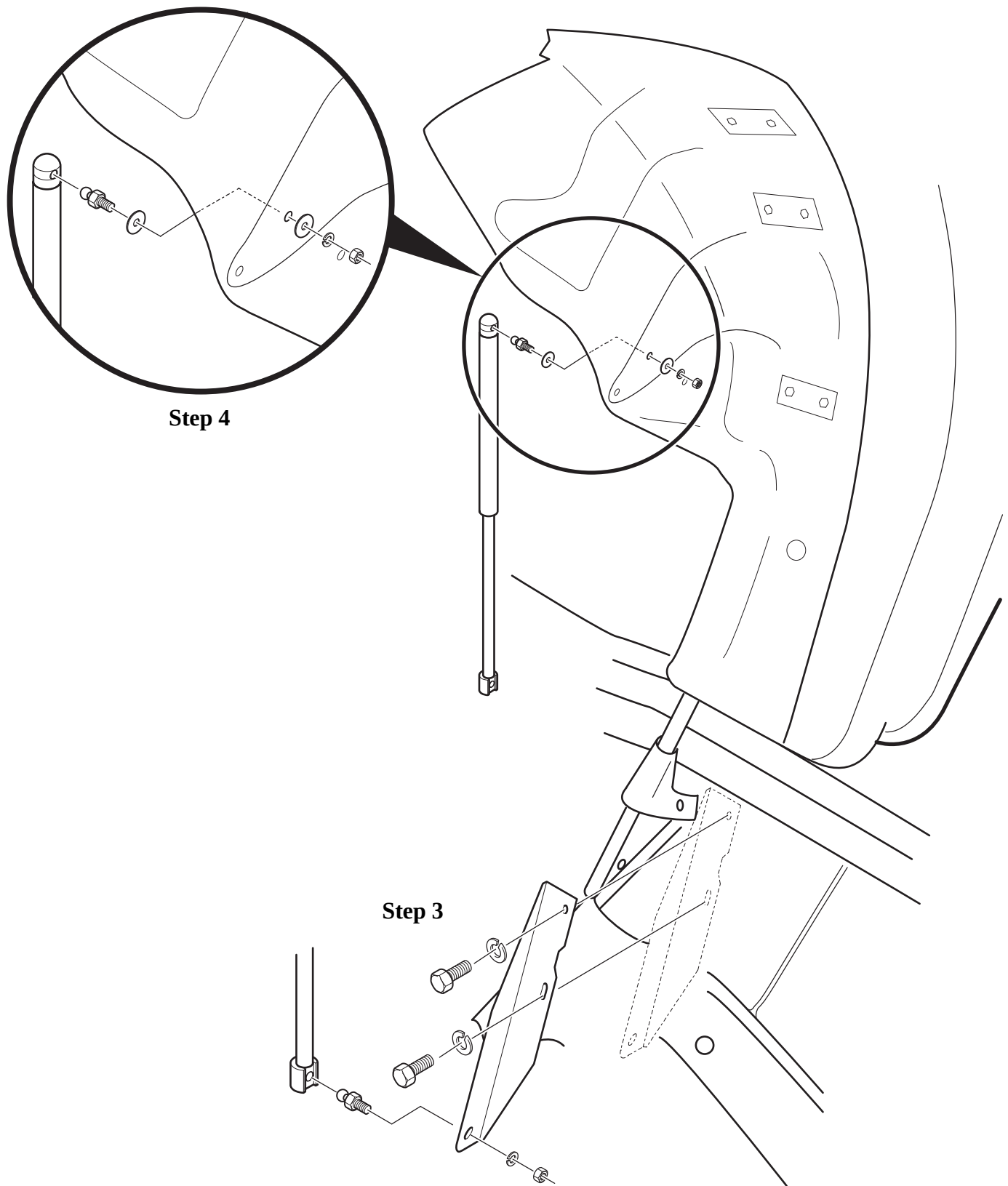

6. Now remove the Factory Prop, and repeat the above steps to install the left hand side.

7. Carefully pull the bonnet down and don't allow it to slam shut. Note: New Gas Springs will feel very stiff at first. They will soften up over time and with use.

